

REVISIONS			
REV.	DESCRIPTION	DATE	APPROVED
-	NEW RELEASE	-	-
1	MOUNTING BRACKET WAS FABRICATED NOW PURCHASED. PLATE WASHERS WERE FABRICATED NOW PURCHASED.	4/20/2026	F. BRYANT

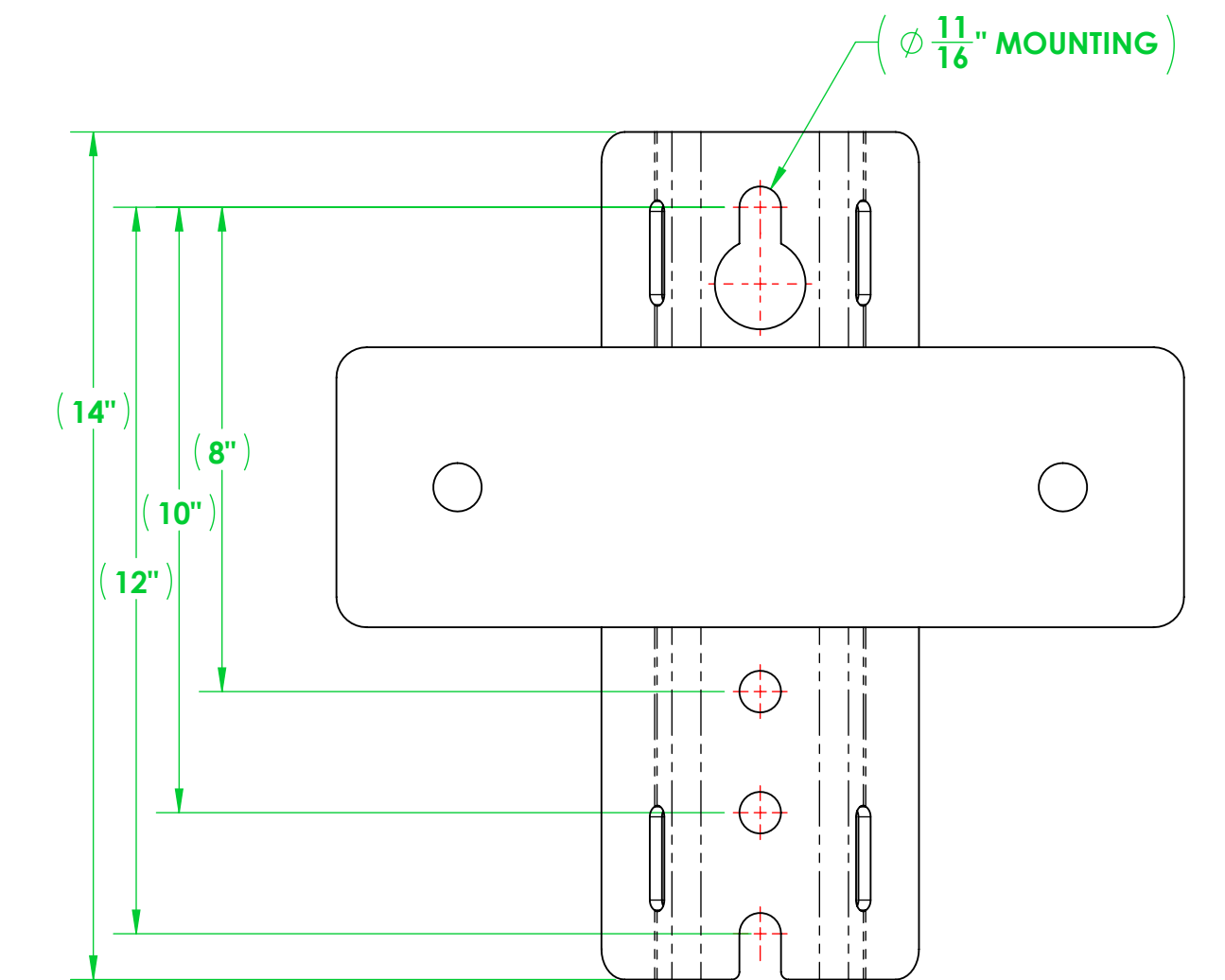

SEE DETAIL A

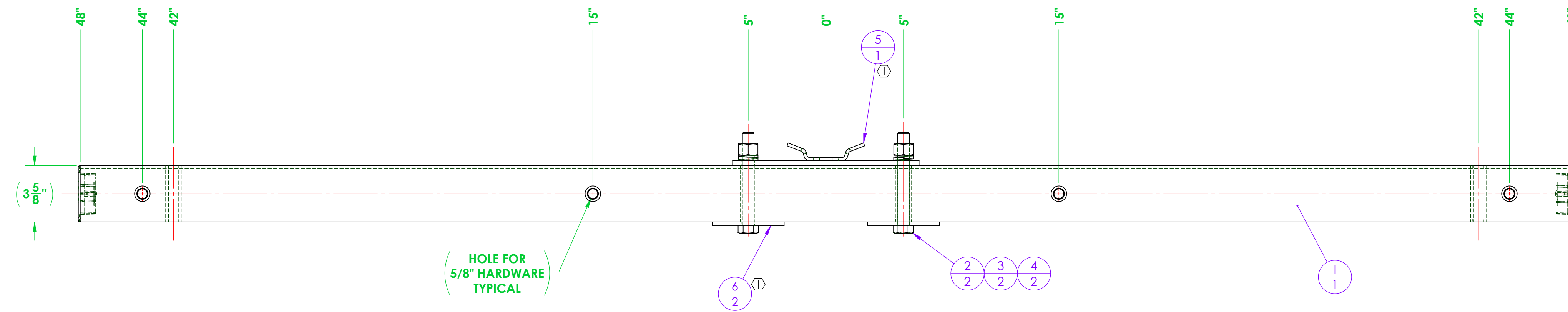
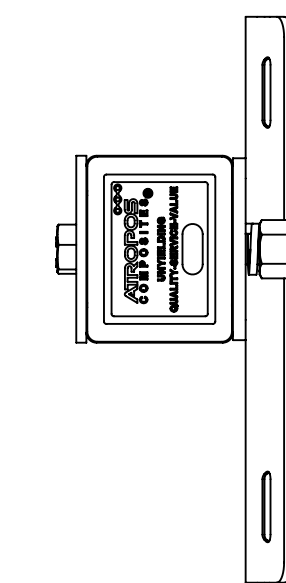
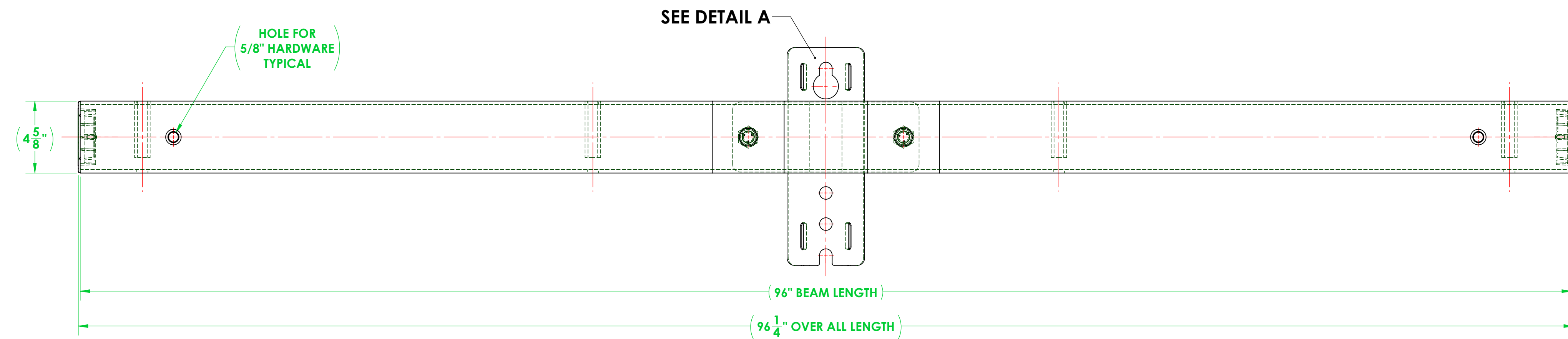

ITEM NO.	PART NUMBER	DESCRIPTION	QTY.
1	3401A096-T011-XR03 CA	ASSEMBLY, RUS, 3401, CROSSARM, TANGENT, 8 FT, AMERMEIN	1
2	A616-0020-02	BOLT, HEX, 3/4"-10 X 6.00" LONG, HOT DIPPED GALVANIZED STEEL, 1-1/8" DRIVE	2
3	A616-0042-01	LOCK WASHER, FOR 3/4" SCREW, 0.766" ID, 1.265" OD, 0.188" THICK, HOT-DIPPED GALVANIZED STEEL	2
4	A616-0019-02	EXTREME STRENGTH NUT, HEX, 3/4"-10, 2H, HOT-DIPPED GALVANIZED	2
① 5	A700-0042	CROSSARM MOUNTING BRACKET, TANGENT, 3400 SERIES	1
① 6	A700-0047	WASHER, SQUARE, 4.625" X 4.625" X 0.25 THICK WITH 0.81 THRU HOLE	2

GENERAL NOTES		UNLESS OTHERWISE SPECIFIED		NAME	DATE
DIMENSIONS ARE IN INCHES		STANDARD TOLERANCES		DRAWN	F. BRYANT
FRACTIONAL: ±1/32		CHECKED		TJS	10/13/2025
ANGULAR: MACHINED: ±0.5° BEND: ±2°		ENG APPR.			
TWO PLACE DECIMAL: ±0.03		MFG APPR.			
THREE PLACE DECIMAL: ±0.005		Q.A.			
INTERFERENCE GEOMETRIC TOLERANCING PER ANSI Y14.5		PROPRIETARY AND CONFIDENTIAL			
MATERIAL		THE INFORMATION CONTAINED IN THIS DRAWING IS THE SOLE PROPERTY OF VETURIO. ANY REPRODUCTION IN PART OR AS A WHOLE WITHOUT THE WRITTEN PERMISSION OF VETURIO IS PROHIBITED.			
FINISH		SCALE: 1:8			
DO NOT SCALE DRAWING		SIZE DWG. NO.		REV	
		D 3401A096-T011-XR03		1	
		WEIGHT: 48.93		SHEET 1 OF 1	

ATROPOS
COMPOSITES
12208 MISSOURI BOTTOM ROAD, HAZELWOOD, MO 63042
PHONE: 314.714.4001 FAX: 314.895.1943
SALES@LABYRINTH-TECH.COM

TITLE:
ASSEMBLY, RUS, 3401, TANGENT CROSSARM WITH GAIN, 8' TYPE 3 DRILL PATTERN